

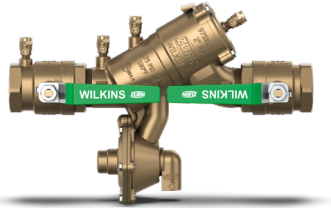

Principles of Backflow Prevention

Zurn Wilkins Backflow Preventers

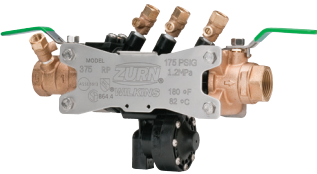
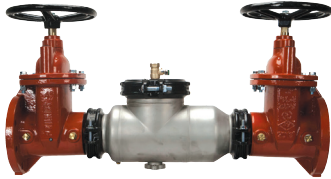

by **Zurn ELKAY** Water Solutions

Time Tested, Contractor Trusted

From compact dimensions to mission-critical applications, our patented backflow preventers lead the industry in ease of install, maintenance costs, and reliability under all sorts of pressure. We focus on safety and control, so you can focus on your business.

Did you know the majority of waterborne illnesses could be avoided with a properly working plumbing system?

High-performing backflow preventers can help protect the integrity of your system and drinking water. This brochure walks through the terminology, selection criteria, and pro installation tips to encourage water safety and control within your building.

What Is Backflow?

Backflow is the undesirable reverse flow of water or mixture of water and other liquids, gases and contaminants into the potable water system.

When Does Backflow Occur?

Backflow is caused by pressure changes, including conditions of gravity, vacuum, or other pressure changes. There are two factors that contribute to reversal of flow in pipelines. One is backsiphonage and the other is backpressure.

Backsiphonage conditions exist when there is a negative or sub-atmospheric pressure in the supply piping, allowing downstream substances to be siphoned into the potable water supply. Under-sized pipes, pipeline breaks, and high withdrawal rates can create vacuums, which contribute to the occurrence of backsiphonage.

Backpressure conditions exist when a pressure higher than the supply is created in the downstream piping, allowing downstream substances to be pushed into the potable water supply. Backpressure can occur when higher pressures downstream are generated by pumps, thermal expansion, and elevation.

What is a Cross-Connection?

A **cross-connection** is a physical or potential connection between a drinking water system and a source of contamination.

Physical connection examples include fire sprinkler and irrigation system or beverage machines and dialysis equipment. An example of a potential connection would be a hose lying next to a swimming pool. While the hose does not yet create a cross-connection, it would if it became submerged in the pool.

If cross-connections are not properly protected, a backflow incident could contaminate a drinking water system.

In applications where cross-connections are necessary, backflow prevention solutions are too.

Assemblies vs. Devices

Mechanical backflow prevention devices and assemblies offer the best protection against cross-connection hazards.

Backflow prevention assemblies consist of an inlet and outlet shut-off valve and test cocks to facilitate testing of the assembly while it is in its functional in-line position.

Backflow prevention devices prevent backflow by stopping the reversal of flow, and are not testable once installed because they do not have inlet and outlet shut-off valves or test cocks.

Containment and Isolation

An effective cross-connection control program will include requirements for both premise containment (meter or service protection) and isolation (internal protection).

Service protection is installed on a water connection at the point where the water purveyor transfers control of the water to the consumer's water system.

Internal protection is installed in the consumer's potable water system at the point of use of the water.

Standards, Approvals, and Listings

Approval agencies, representing many diverse geographical areas and levels of government, require performance criteria regarding the function, manufacturing, installation, testing and maintenance of backflow prevention devices and assemblies.

These standards ensure the integrity of the drinking water by addressing each mechanical function and materials of the backflow preventers.



475ST Stainless Steel n-Pattern Reduced Pressure Principle Assembly installed to protect against backsiphonage and backpressure in high hazard applications

Selecting a Backflow Preventer

Zurn provides numerous types of backflow preventers to meet industry standards, which are set to provide the right level of protection depending on system conditions.

Types of Backflow Preventers

Backflow prevention devices and assemblies include:

- Atmospheric Vacuum Breakers
- Dual Check Valves
- Pressure Vacuum Breakers
- Double Check Valve Assemblies
- Reduced Pressure Principle Backflow Assemblies

Each backflow preventer provides protection based on the specific application.

System Characteristics

System characteristics address the hydraulic requirements specific to the application.

Backpressure versus backsiphonage

Continuous pressure versus non-continuous pressure

- Non-continuous pressure cannot be applied for more than 12 hours continuously during a 24 hour time period

Existing conditions of pressure loss

- Pressure loss within a plumbing system occurs from pipe, fittings, and valves
- Backflow preventers, which utilize check valves, contribute to pressure loss
- Flow curves provide pressure loss data on backflow preventers

Elevation in the piping system

- The weight of water in a column contributes approximately 1 psi for every 2.8 inches of column height, so the pressure at the bottom of the column is greater than the pressure at the top.
- Ten-story building can lose almost 35 psi in water pressure from the ground floor to the top floor.

Degree Of Hazard

Degree of hazard can help you determine the proper solution.

Low-hazard application: potential backflow can pollute the drinking water

- **Pollution** refers to undesirable effects to the water that will not cause illness, such as discoloration, smell or taste.

High-hazard application: potential backflow can contaminate the water supply

- **Contamination** refers to any impairment to the quality of water that can result in illness.

A **lethal hazard** involves radioactive material or raw sewage. An air gap is the only effective means of protecting against lethal hazards. Under no circumstance would a mechanical backflow preventer be used to protect against a lethal hazard.

Application Types

The **application types** and industry, such as fire protection, irrigation, waterworks, and plumbing, adhere to their own particular requirements. Fire sprinkler systems may require detector assemblies, and irrigation systems may require products that are not used universally in plumbing systems.

Each application is also unique in regards to flow as well. Plumbing and waterworks require consistent flow of water. Irrigation requires flow perhaps 2% of the time and the remaining 98% of the time maintains a static condition. Fire protection must stand ready for action with 100% static water pressure. Each application can present a unique situation, which will affect a backflow preventer differently.

Installation Types

Installation types include outdoor, indoor, below grade (pit installations), horizontal, and vertical installations.

Facilities that require uninterrupted supply of water, such as hospitals, resort hotels, or industrial applications, will require multiple connections or manifold assemblies.

- Outdoor installations face the potential of vandalism, theft, soil erosion, and freezing temperatures. Protective enclosures can help to mitigate some of these issues.
- Indoor installations might need to address the issue of water discharge. Atmospheric and Pressure Vacuum Breakers routinely spill water during system startup. Reduced Pressure Principle Backflow Assemblies are designed to spill water to prevent backflow.
- Below-grade installations can be convenient, but are limited to certain types of backflow preventers. Proper maintenance care and testing procedures should be followed.
- Horizontal installations are the most common.
- Vertical installations are limited on the flow direction and exclude Reduced Pressure Principle Backflow Preventers.

Compact dimensions and easy-to-access designs can speed up your maintenance and repair tasks.

Testable Backflow Prevention Assemblies vs. Non-Testable Backflow Devices

Local authority ultimately determines whether to use a testable backflow prevention assembly or non-testable backflow device.

Typically, **testable backflow prevention assemblies** are installed to prevent contamination of public potable water supply.

Non-testable backflow devices are usually used for internal system protection applications. The testable assembly is still at the service connection.



975XL3 Reduced Pressure Principle Backflow Preventer

Determining Your Backflow Preventer Use

Compare the application and functionality to find the applicable Zurn Wilkins models for your system.

TYPE	APPLICATION	MODEL	APPLICATION					
			BACKSIPHONAGE	BACKPRESSURE	CONTINUOUS PRESSURE	LOW HAZARD	HIGH HAZARD	TESTABLE
Reduced Pressure Principle	Irrigation, Plumbing, Waterworks, Industrial, Medical, Fire Sprinkler	975XL/975XL2/975XL3 975XL2SE 375XL/375 375AST/375A/375 475ST/475 475STV/475V 475STR/475STRV	✓	✓	✓		✓	✓
Reduced Pressure Principle with Wireless Monitor - Connected Backflow Option	Indoor applications where undetected discharge could cause water damage	375W1/375AW1 375ASTW1/FCIS FCISA/FCICAST	✓	✓	✓		✓	✓
Reduced Pressure Principle Detector Assembly	Fire Sprinkler System Supply Main. Detects Leaks and Unauthorized Use of Water	375ASTDA/375DA 375ASTDA/375ADA 475STDA/475DA 475STDV/475DAV 475STDAR 475STDARV 975DA	✓	✓	✓		✓	✓
Double Check Assembly	Irrigation, Plumbing, Waterworks, Industrial, Medical, Fire Sprinkler	350XL/350 350AST/350A/350 450ST/450/450STR	✓	✓	✓	✓		✓
		950XL3 950XLT2/950XL	✓	✓	✓	✓		✓
Double Check Detector Assembly	Fire Sprinkler, System Supply Main. Detects Leaks and Unauthorized Use of Water	350ASTDA/350DA 350ADA 450STDA/450DA 450STDAR 950XLTDA(BF)	✓	✓	✓	✓		✓
Dual Check	Residential Supply Lines and Fire Sprinkler Systems	700XL 700XLFP 705	✓	✓	✓	✓		
Dual Check with Atmospheric Vent	Boiler Feed Lines, Laboratory Equipment, Residential	760	✓	✓	✓	✓		
Dual Check with Vent	Carbonated Beverage Systems, Beverage Vending Machines	740	✓	✓	✓	✓		
In-Line Spring-Loaded Check Valve	Irrigation, Pump and Water Hammer Applications	40XL2	✓	✓	✓	✓		
Single Check		310	✓	✓	✓	✓		
Single Check Detector Assembly	Fire Sprinkler System Supply Main. Detects Leaks and Unauthorized Use of Water	310DA	✓	✓	✓	✓		
Pressure Vacuum Breaker	Irrigation and Lawn Sprinkler Systems	420XL 460XL 710 720A	✓		✓	✓	✓	✓
Atmospheric Vacuum Breaker	Laboratory Sinks, Lawn Sprinklers, Commercial Laundry	35XL	✓			✓	✓	
Hose Connection Vacuum Breaker	Hose Bibbs, Service Sinks, Lab Sinks, Hydrants	BFP-8F BFP-9 730 735	✓			✓		

Types of Backflow Preventers

Atmospheric Vacuum Breaker (AVB)

AVB contains a float check, check seat and air inlet port. The water flow into the body causes the float to rise and close the air inlet port. When flow stops, the float falls and forms a check against backsiphonage. At the same time, the air inlet port allows air to enter and satisfy the vacuum. The shutoff valve acts immediately and integrally.

SYSTEM CHARACTERISTICS

- Noncontinuous pressure application (no more than 12 hours of pressure per 24 hour period)
- Backsiphonage condition only
- Provides protection in low- and high-hazard situations

TESTING

This device is not testable once installed.

HEIGHT REQUIREMENT

Installed 6" above the highest point in the water system downstream



35XL

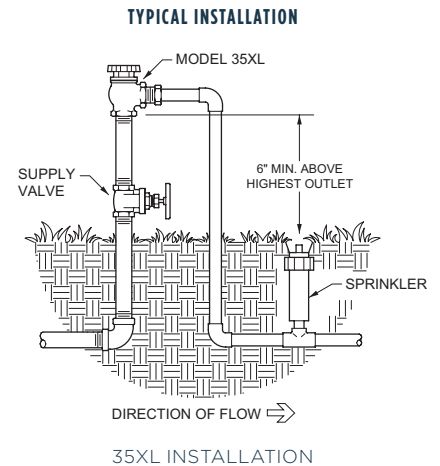

Pressure Vacuum Breaker (PVB)

A **PVB** is an assembly containing an independently acting, internally loaded check valve with an independently acting loaded air inlet valve, located on the discharge side of the check valve. A PVB shall have two resilient-seated isolation valves attached at each end of the assembly and two properly located resilient-seated test cocks.

SYSTEM CHARACTERISTICS

- Continuous and non-continuous pressure applications
- Backsiphonage condition only
- Provides protection in low and high hazard situations

TESTING

- 1 The air inlet valve shall open when the pressure in the body is no less than 1.0 psi above atmospheric pressure. And, the air-opening valve shall be fully open when the water drains from the body.
- 2 The check valve shall be drip tight in the normal direction of flow when the inlet pressure is 1 psi and the outlet pressure is atmospheric.

HEIGHT REQUIREMENT

Installed 12" above the highest point in the water system downstream with adequate clearance for testing and maintenance.



720A

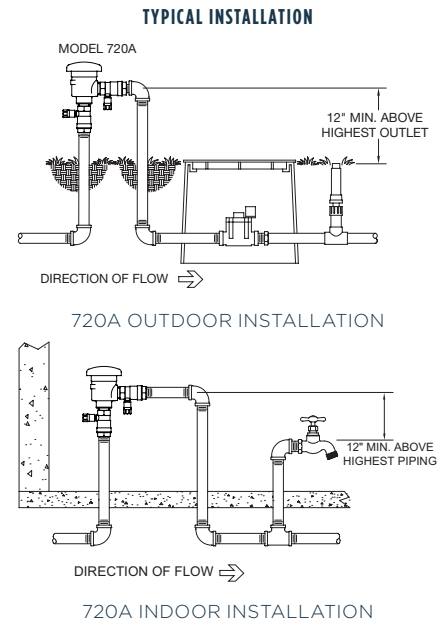

460XL

Spill Resistant Vacuum Breaker (SVB)

SVBs are the same as pressure vacuum breakers, except they are less prone to discharge and used for indoor applications.

During startup and operation, a separate diaphragm seals the air inlet from the water supply to prevent spillage. The assembly provides protection under constant pressure where a potential health hazard exists.

Dual Check Valve and Dual Check with Atmospheric Port

Dual Checks are designed for use in low-hazard applications where a fully approved, testable backflow preventer is not required. Check with the local authority having jurisdiction for acceptance.



700XL

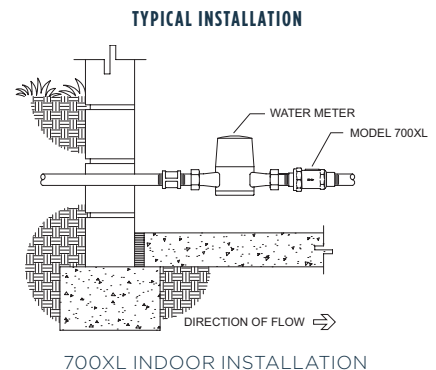

Double Check Valve Assembly (DC)

A DC contains two independently acting approved check valves, four resilient-seated test cocks, and two resilient-seated isolation valves.

SYSTEM CHARACTERISTICS

- Continuous and non-continuous pressure applications
- Backsiphonage and backpressure conditions
- Provides protection in low hazard situations

TESTING

- 1 The no. 1 check valve shall be tight against reverse flow under all pressure differentials. The static differential pressure across the no. 1 check valve must be at least 1 psid.
- 2 The no. 2 check valve shall be tight against reverse flow under all pressure differentials. The static differential pressure across the no. 2 check valve must be at least 1 psid.

TYPICAL INSTALLATION

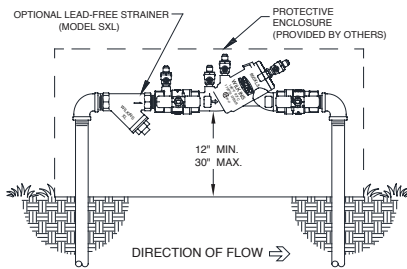

950XL3 OUTDOOR INSTALLATION

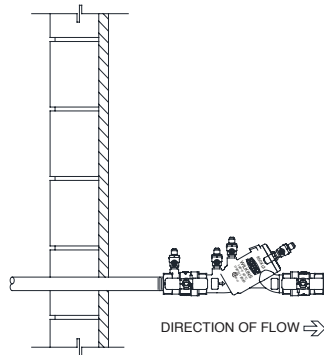

950XL3 INDOOR INSTALLATION

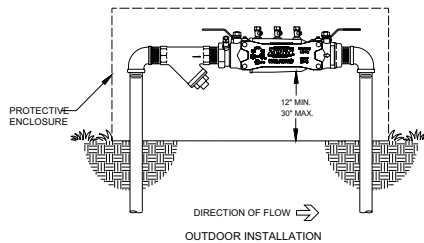

350XL OUTDOOR INSTALLATION



950XL3



350XL



350AST

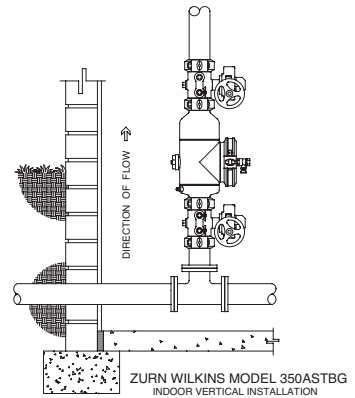

350ASTBG INDOOR INSTALLATION

Double Check Detector Assembly (DCDA)

A DCDA is a specially designed assembly composed of a line-sized approved double check valve assembly, with a specific by-pass water meter, and a meter-sized approved double check valve assembly. The meter shall register accurately for all flows up to and including two gpm.

SYSTEM CHARACTERISTICS

- Continuous and non-continuous pressure applications
- Backsiphonage and backpressure condition
- Provides protection in low hazard situations only

TESTING

- 1 The static differential pressure across the no. 1 check valve must be at least 1 psid.
- 2 The static differential pressure across the no. 2 check valve must be at least 1 psid.

HEIGHT REQUIREMENT

Install between 12"-30" above the floor or finished grade with adequate clearance for testing and maintenance. If installation is in a pit or vault, provide ample drainage to ensure the backflow preventer does not become submerged.

Account for required side clearance from the wall of Double Check and Reduced Pressure Principle Assemblies (1/2"-3") are 24" from side test cocks, 12" from top mounted test cocks, with 24" access from one side. For sizes 4" and above, double these requirements. The weight of the checks must also be considered, especially if you are looking at a vertical installation. The check assembly weight for an 8"-10" device may require lifting assistance.



350ASTDABF

TYPICAL INSTALLATION

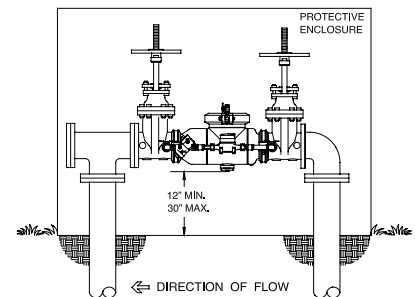

350ASTDAOSY OUTDOOR INSTALLATION

Reduced Pressure Principle Assembly (RP)

A **RP** is an assembly containing two independently acting approved check valves together with a hydraulically operated, mechanically independent differential pressure relief valve located between the two check valves.

SYSTEM CHARACTERISTICS

- Continuous and non-continuous pressure applications
- Backsiphonage and backpressure conditions
- Provides protection in low and high hazard situations

TESTING

- 1 The pressure differential relief valve must operate to maintain the zone between the two check valves at least 2 psi less than the supply pressure.
- 2 The no. 2 check valve shall be tight against reverse flow under all pressure differentials.
- 3 The static pressure drop across check valve No. 1 shall be greater than the relief valve opening point (test no. 1), and at least 5.0 psid.

TYPICAL INSTALLATION

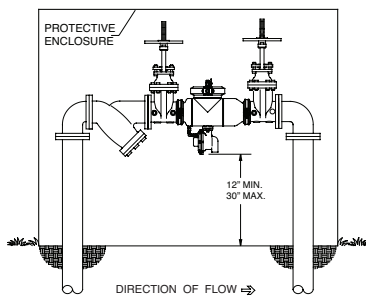

375ASTOSY OUTDOOR INSTALLATION

HEIGHT REQUIREMENT

Install between 12"-30" above the floor or finished grade with adequate clearance for testing and maintenance.

Account for required sided clearance from the wall of Double Check and Reduced Pressure Principle Assemblies (1/2"-3") are 24" from side test cocks, 12" from top mounted test cocks, with 24" access from one side. For sizes 4" and above, double these requirements. The check assembly weight for an 8"-10" device may require lifting assistance.

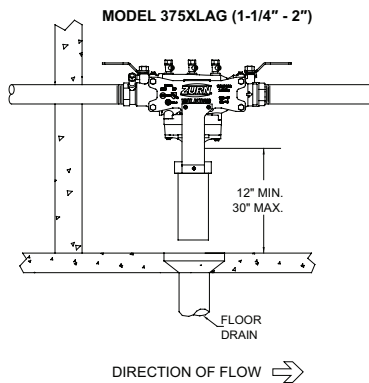

375XL INDOOR INSTALLATION

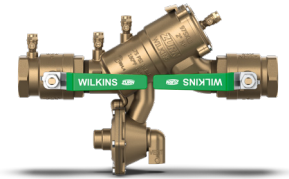

975XL3

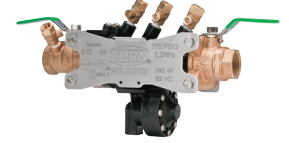

375XL

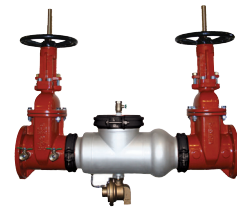

375AST

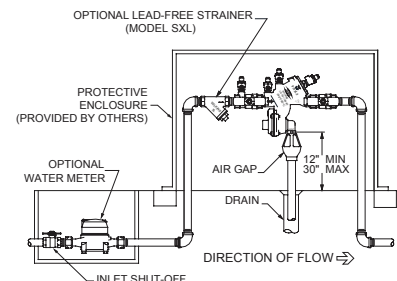

975XL3 OUTDOOR INSTALLATION

Reduced Pressure Principle Detector Assembly (RPDA)

A **RPDA** is a specially designed assembly composed of a line-sized approved reduced pressure principle backflow assembly, with a specific by-pass water meter and a meter-sized approved reduced pressure principle backflow prevention assembly. The meter shall register accurately for all flows up to and including two gpm. The meter shall show a registration for all flows above two gpm.

SYSTEM CHARACTERISTICS

- Continuous and non-continuous pressure installations
- Backsiphonage and backpressure conditions
- Provides protection in low and high hazard situations

TESTING

- 1 The pressure differential relief valve must operate to maintain the "zone" between the two check valves at least 2 psi less than the supply pressure.
- 2 The no. 2 check valve shall be tight against reverse flow under all pressure differentials.
- 3 The static pressure drop across check valve no. 1 shall be greater than the relief valve opening point (test no. 1), and at least 5.0 psid.

HEIGHT REQUIREMENT

Installed between 12"-30" above the floor or finished grade with adequate clearance for testing and maintenance.

Side clearance requirement from the wall of Double Check and Reduced Pressure Principle Assemblies (1/2"-3") are 24" from side test cocks, 12" from top mounted test cocks, with 24" access from one side. For sizes 4" and above, these requirements are doubled. The check assembly weight for an 8"-10" device may require lifting assistance.



375ASTDABG

TYPICAL INSTALLATION

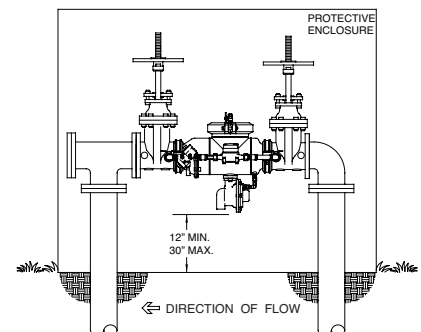

375ASTDA OUTDOOR INSTALLATION

How to Read Performance Curves

Performance curves depict the relationship of pressure drop and flow rate throughout its full range operation. Flow rates beyond the usable range will have velocities destructive to the piping system or excessive pressure loss. The basis for flow capacity and pressure loss in a backflow prevention assembly begins at zero gpm and goes up to the industry standard by the American Water Works Association. This maximum rate is known as rated flow. Assemblies that fail to meet the required flow rates or exceed the maximum pressure drop at any point up to the rated flow will not be approved.

All Zurn Wilkins backflow prevention assembly performance curves are constructed with the flow rate in gallons per minute (gpm) or liters per second (l/s) on the horizontal axis and the pressure loss in pounds per square inch (psi) or kilopascals (kpa) on the vertical axis. Additionally, a diamond will be placed on the curve to indicate the maximum rated flow for each given assembly, according to its pipe size.

Example

Find the pressure loss exhibited by a 4" 350A double check valve assembly while the valve is flowing at 400 gpm (see chart below).

Solution

Follow the horizontal axis out to 400 gpm. Next, move upward until the 400 gpm axis intersects the 4" 350A curve. At this juncture, moving to the left, read the pressure loss from the vertical axis that corresponds with the intersection of the 400 gpm axis and the 4" 350A curve. The pressure loss at 400 gpm is taken to be 3.5 psi. Also, from the curve, we see that the diamond is at the value of 500 gpm. Therefore, the maximum rated flow of a 4" Zurn Wilkins 350A is 500 gpm.

Note: To properly interpret the following Zurn Wilkins backflow performance curves, the flow rates on the top are indicated in "liters per second" and the bottom flow rates are in "gallons per minute."

EXAMPLE FLOW CURVES

MODEL 350A 2-1/2", 3" & 4" (STANDARD & METRIC)

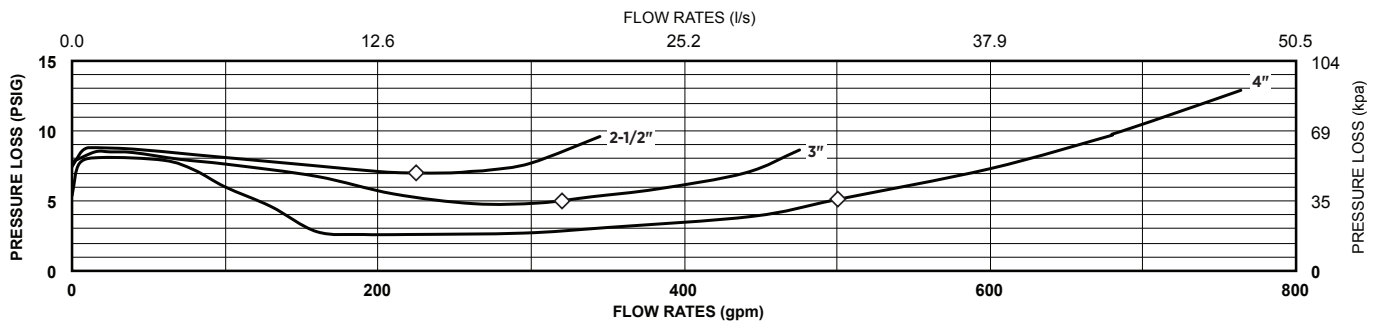

MODEL 350A 6", 8" & 10" (STANDARD & METRIC)

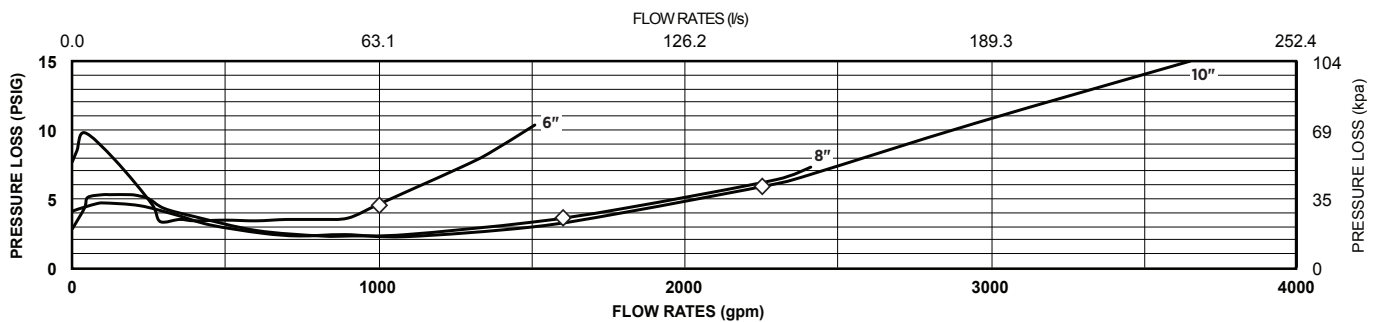

Operating Principles of the Zurn Wilkins Model 975XL Reduced Pressure Principal Backflow Preventer

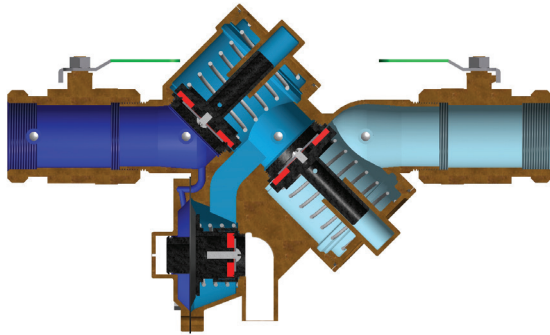

Static (No Flow) Condition

Both check valves are closed in a static (no flow) condition. Pressure on the supply side of the valve is approximately 8 psi higher than the pressure in the reduced pressure zone, therefore the relief valve is held in a closed position.

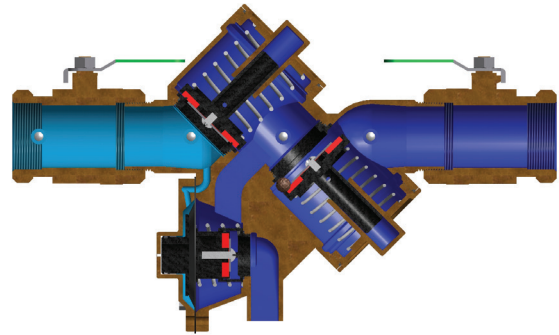

Backpressure with 2nd Check Fouled

Potentially contaminated liquid will flow into the reduced pressure zone of the valve. As the zone pressure increases to within 2 psi of the inlet pressure, the relief valve begins to open and discharges to the atmosphere.

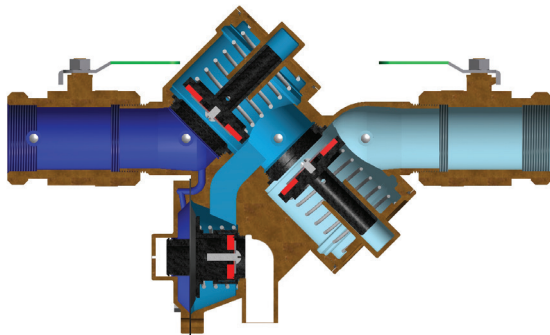

Normal Flow

Both check valves are open in a normal flow condition. The relief valve is held in a closed position because of the higher pressure on the supply side of the valve. Pressure in the reduced pressure zone is approximately 8 psi lower than the supply side of the valve.

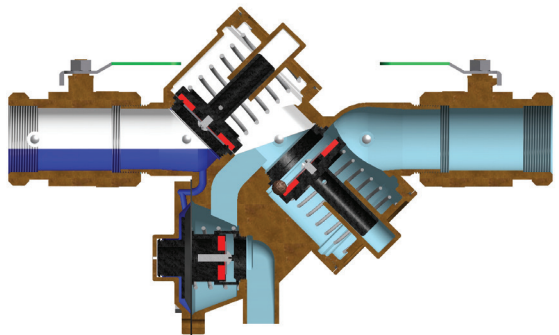

Backsiphonage with 2nd Check Fouled

The inlet pressure becomes negative or subatmospheric. Because the pressure on the supply side is lower than the zone pressure, the relief valve goes to a full open position and discharges to the atmosphere.

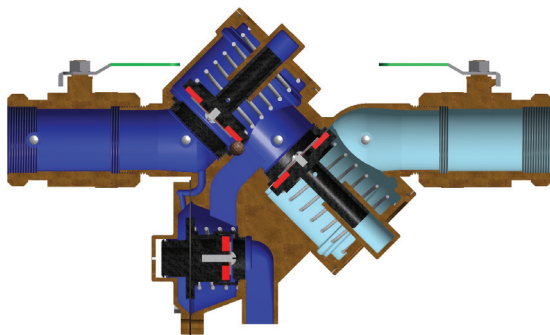

Static Condition with 1st Check Fouled

Fluid will leak from the inlet into the reduced pressure zone. As the zone pressure increases to within 2 psi of the inlet pressure, the relief valve begins to open and discharges to the atmosphere. The amount of fluid discharging from the relief valve is proportional to the extent of the foul across the 1st check.

KEY:

- Higher pressure
- Medium (zone) pressure
- Lower pressure
- Atmospheric pressure

DIRECTION OF FLOW

Reduced Pressure Backflow Assembly Troubleshooting Guide

Below is a simple troubleshooting method that does not require a test kit to identify the root causes for relief valve discharge.

After observing water discharge from relief valve port:

- 1 Close #2 shutoff valve.
 - If discharge stops, the problem is a fouled second check while under backpressure.
- 2 If discharge continues, open #4 test cock.
 - If discharge stops or is reduced, the problem is a fouled first check.
- 3 If discharge continues, the problem is most likely in the relief valve.

Solution

Disassemble and clean affected components and remove debris from the backflow preventer.

If you are still experiencing issues after completing these initial troubleshooting steps, contact the Zurn Customer Care department for further assistance.

Accessories



Backflow Assembly Test Kits (TG-3, TG-5)



Ball Type Test Cock w/SAE Flair Fitting (860XLFT)



Quick Test Fittings (QT, QTP)



RP Air Gap (AG)



Valve Setters



350/375 (1/2" - 2") Blow-out Flush Fitting



950XL3/975XL3 Winterization Flush Tool (900XL3WF)

REFERENCES

¹ Centers for Disease Control and Prevention (August 14, 2015). Surveillance for Waterborne Disease Outbreaks Associated with Drinking Water – United States, 2011–2012 (64(31):842–848). Retrieved from <http://www.cdc.gov/mmwr/preview/mmwrhtml/mm6431a2.htm>

Connected Backflow Preventers

Zurn Connected Backflow Preventers monitor performance from flow to pressure to valve discharge. You and your team members can act in real time, before there's ever a real problem. Even more, you'll gain insights and a little more predictability into your day.

System Characteristics

- Integral relief valve monitoring
- Real-time alerts for preset discharge mode
- High-hazard protection for potable applications
- Water rate monitoring and recording

Testing

- PlumbSMART will let you know when your system needs maintenance

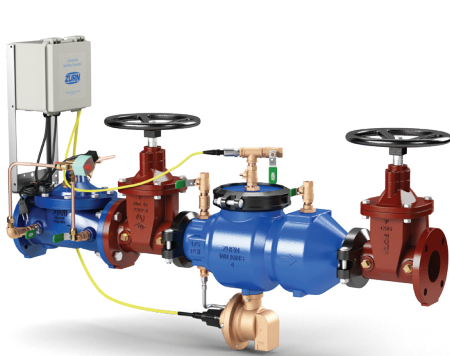

FCISA

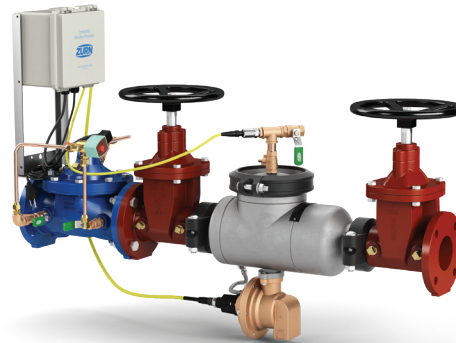

FCISAST

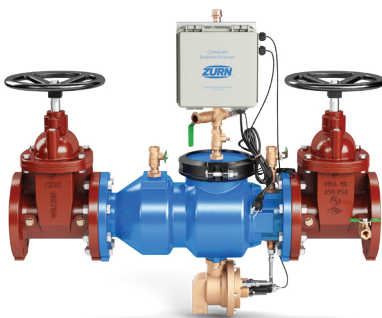

375W1



375AW1





375ASTW1

Choose Your Connected Backflow Preventer

Do you want to know if there is a spike or drop in pressure any time of day or would automatic shutoff help you sleep a little more soundly at night?

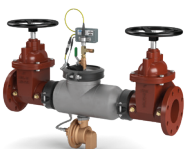
The capabilities that matter most depend on how you operate and where your backflow preventer resides. Use this comparison guide to determine the ideal solution for your needs.

	 Connected Double Check	 Connected Reduced Pressure Principle	 Connected Reduced Pressure Principle with Relief Valve Monitor (W1)	 Connected Flood Control System (FCIS)
Pressure Readings	<input checked="" type="checkbox"/>	<input checked="" type="checkbox"/>	<input checked="" type="checkbox"/>	<input checked="" type="checkbox"/>
Relief Valve Discharge Calculations			<input checked="" type="checkbox"/>	<input checked="" type="checkbox"/>
Flooding Prevention			<input checked="" type="checkbox"/>	<input checked="" type="checkbox"/>
Automatic Water Shutoff				<input checked="" type="checkbox"/>
Connected Flow Meter Option (ZCSM-BTM) available upgrade combined with ZCSM-PF	<input checked="" type="checkbox"/>	<input checked="" type="checkbox"/>		

Connected Remote Pressure Monitor ZCSM-RP

The Zurn Connected Remote Pressure Monitor (ZCSM-RP) allows you to monitor your water pressure and rule out any pressure problems in real time. Simply set high- and low-pressure thresholds for real-time alerts through our secure plumbSMART™ web portal. You and your team can opt into text or email alerts, so you know as soon as they fall beyond your preset parameters. You also receive anytime-anywhere access to system pressure data for trends and predictive maintenance.

- Easily installs and can tie into pipes with t-fittings or can take pressure reads from existing test ports
- Receive real-time alerts based on your customized high- or low-pressure warnings and alerts
- Receive warnings BEFORE there is a major issue and send alerts directly to maintenance team or contractor
- Monitor pressure anywhere and know your water pressure at any location in your building



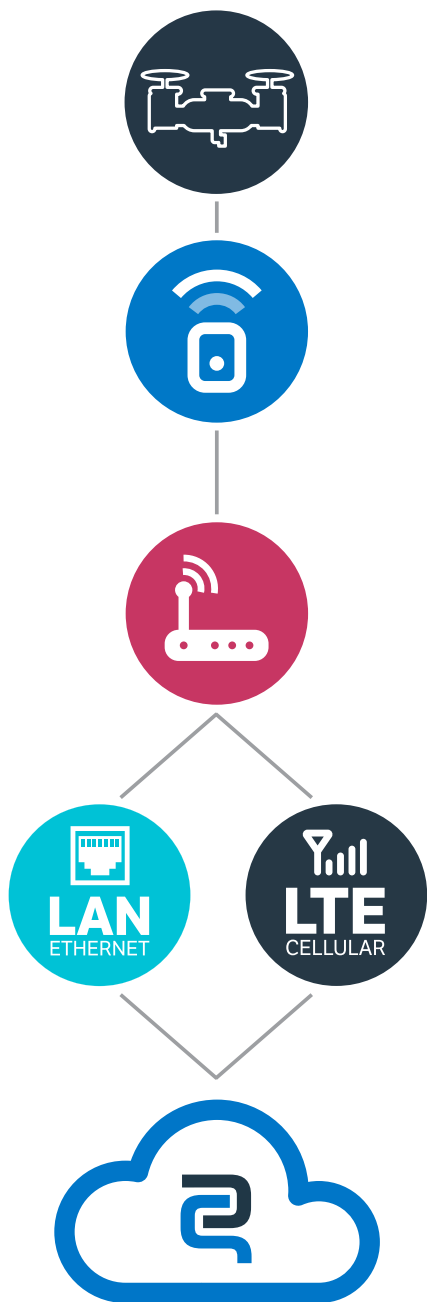

How it Works

Using sensors, Zurn Connected Backflow Preventers monitor performance and offer insights by gathering data.

- Water consumption
- Predictive maintenance
- Severe relief valve discharge
- Pressure and flow rate thresholds

The data collected gets communicated from the sensor to the Zurn Gateway.

- Choose LAN or LTE connection
- Product data moves to secure cloud

The secure Cloud analyzes your data to deliver real-time insights to plumbSMART.

- Log in to plumbSMART
- Act on uncovered product data

Now, you can focus on what's in front of you, not what's in the back of your mind.

Zurn Elkay Water Solutions supplies the industry's widest range of clean water solutions for drinking water, hygiene and sustainable water management. We work with customers around the globe to deliver products and systems that enhance and ensure water quality, safety, hygiene, flow control and conservation.