



# Z160

## 135° SCUPPER DRAIN

SPECIFICATION SHEET

TAG \_\_\_\_\_

Dimensional Data (inches and [mm]) are Subject to Manufacturing Tolerances and Changes Without Notice

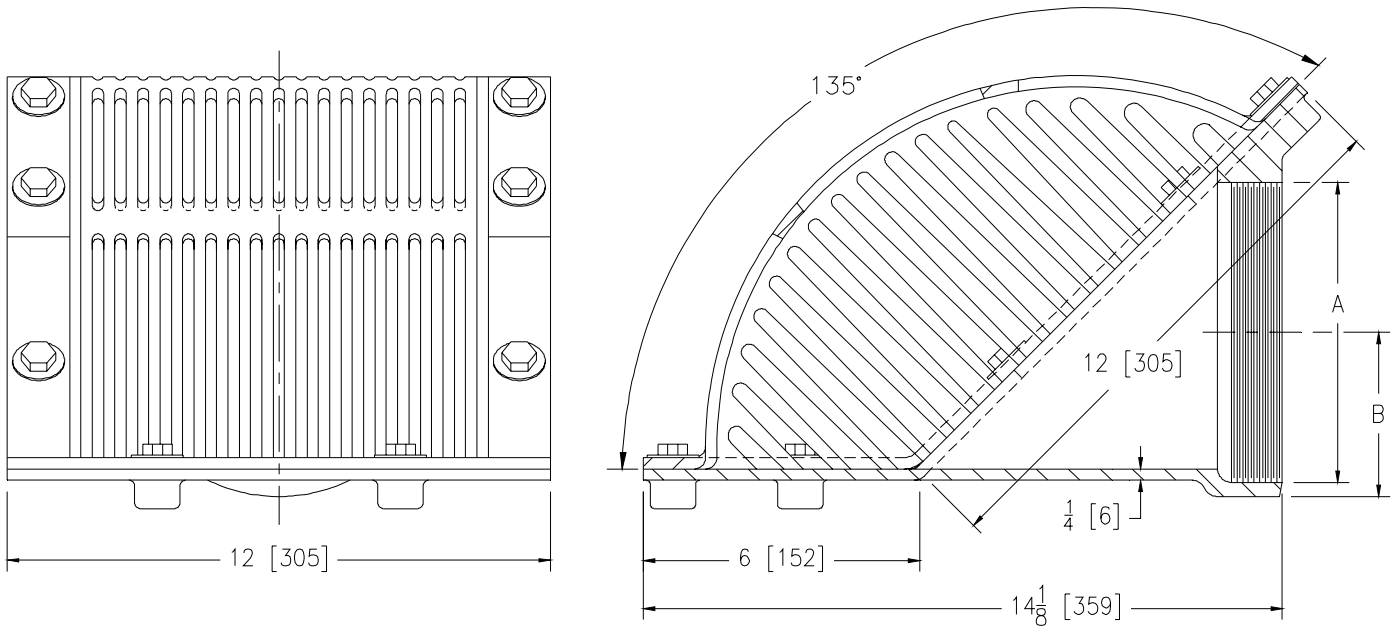

Dimensions in In		Approx. Wt. Lbs. [kg]	Grate Open Area Sq. In. [cm <sup>2</sup> ]
A - Pipe Size	B		
2 [51]	1-1/2 [38]	52 [23]	114 [735]
3 [76]	2-1/16 [52]		
4 [102]	2-9/16 [65]		
5 [127]	3-1/16 [78]		
6 [152]	3-5/8 [92]		

**ENGINEERING SPECIFICATION: ZURN ZRB160**  
 135° Scupper drain, Dura-Coated cast iron body, plain bronze grate with integral membrane clamp.

**OPTIONS** (Check/specify appropriate options)

**PIPE SIZE** (Specify size) **OUTLET**  
 2 thru 6 [51 thru 152] \_\_\_\_\_ IP Threaded

**PREFIXES**

- \_\_\_ ZRB D.C.C.I. Body with Plain Grate\*
- \_\_\_ ZB D.C.C.I. Body with Polished Bronze Grate
- \_\_\_ ZN D.C.C.I. Body with Polished Nickel Bronze Grate

**SUFFIXES**

- \_\_\_ -DA Downspout Adapter
- \_\_\_ -G Galvanized Cast Iron

REV. D	DATE: 10/20/10	C.N. NO. 111897
DWG. NO. 58826	PRODUCT NO. Z160	

\*REGULARLY FURNISHED UNLESS OTHERWISE SPECIFIED